



US005302168A

# United States Patent [19]

[11] Patent Number: 5,302,168

Hess

[45] Date of Patent: Apr. 12, 1994

[54] METHOD AND APPARATUS FOR RESTENOSIS TREATMENT

[76] Inventor: Robert L. Hess, 222 Wyndham Dr., Portola Valley, Calif. 94025

4,815,449 3/1989 Horowitz ..... 600/7  
 4,878,492 11/1989 Sinofsky ..... 128/303.1  
 5,019,075 5/1991 Spears ..... 606/7  
 5,059,166 10/1991 Fischell et al. .... 600/3  
 5,084,002 1/1992 Liprie ..... 600/3

[21] Appl. No.: 755,480  
 [22] Filed: Sep. 5, 1991

Primary Examiner—Lee S. Cohen  
 Assistant Examiner—John P. Lacyk  
 Attorney, Agent, or Firm—Burns, Doane, Swecker & Mathis

[51] Int. Cl.<sup>5</sup> ..... A61N 5/00  
 [52] U.S. Cl. .... 600/3; 606/7  
 [58] Field of Search ..... 600/1-8; 606/7

### [57] ABSTRACT

Method and apparatus for treatment and post-treatment of the stenosed region of an artery after reduction of the region by angioplasty or other means by applying a radioactive dose to said reduced region of the artery by positioning a radioactive dose to the reduced region is disclosed.

[56] **References Cited**  
**U.S. PATENT DOCUMENTS**  
 3,168,092 2/1965 Silverman ..... 128/1.2  
 3,324,847 6/1967 Zoumboulis ..... 128/1.2  
 4,588,395 5/1986 Lemelson ..... 604/59  
 4,697,575 10/1987 Horowitz .  
 4,733,665 3/1988 Palmaz ..... 128/343

6 Claims, 4 Drawing Sheets

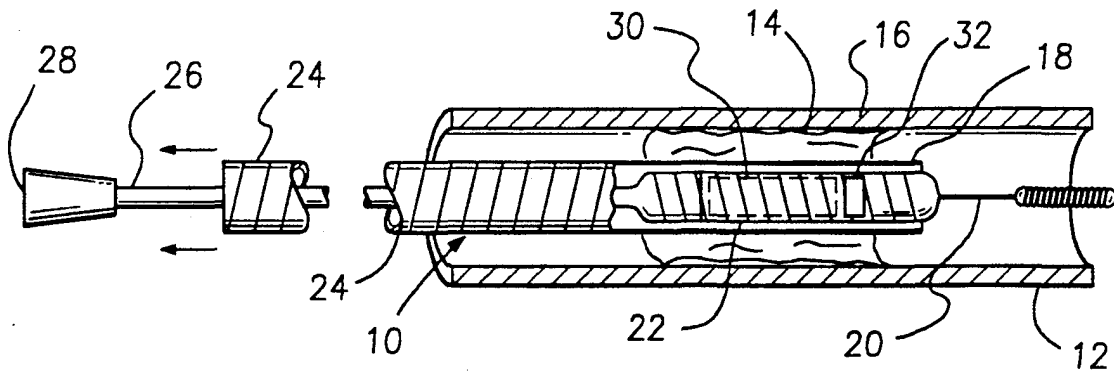

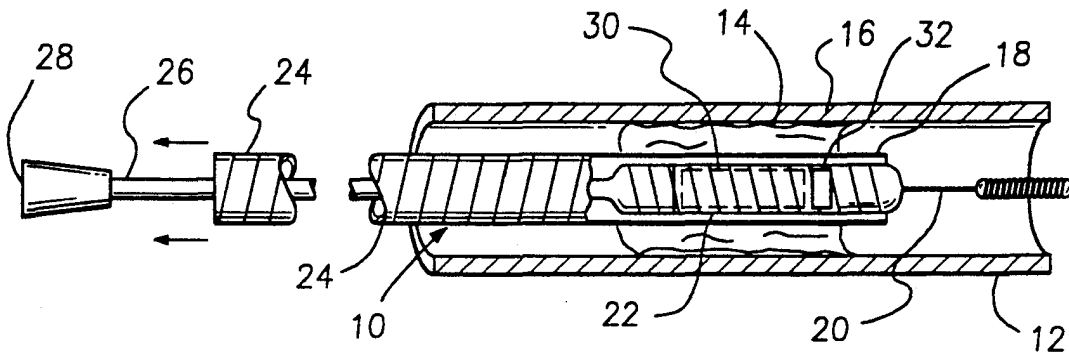

FIG. 1

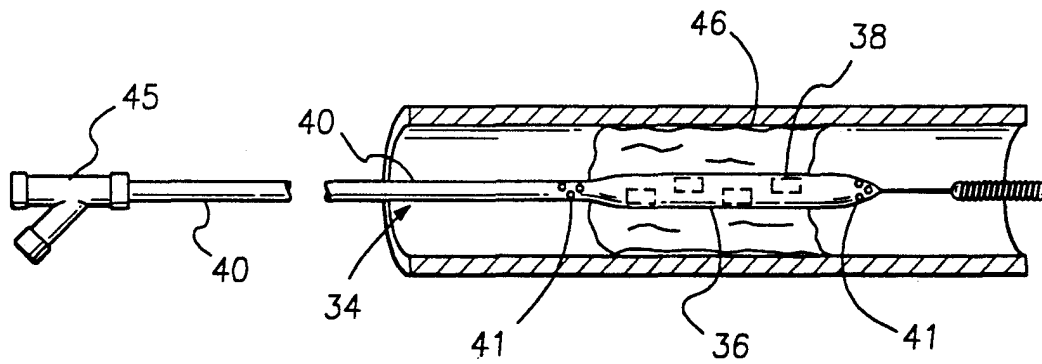

FIG. 2

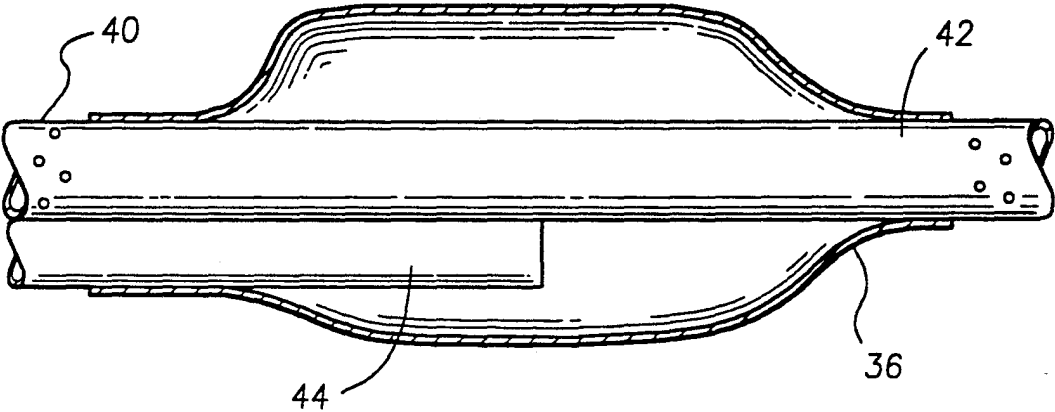

FIG. 3

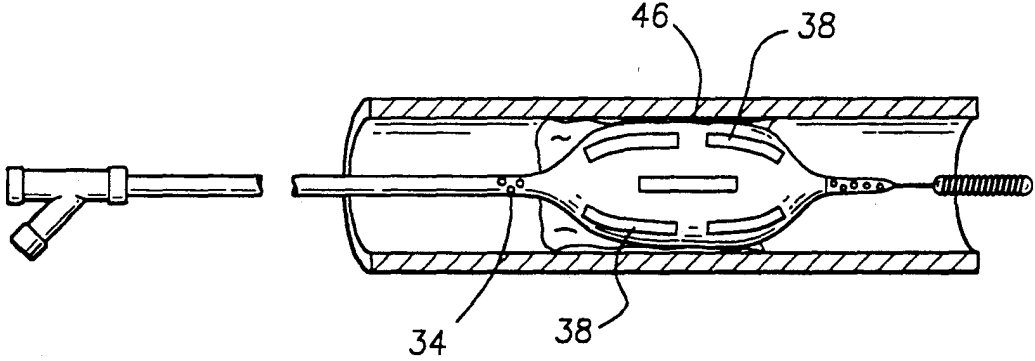

FIG. 4

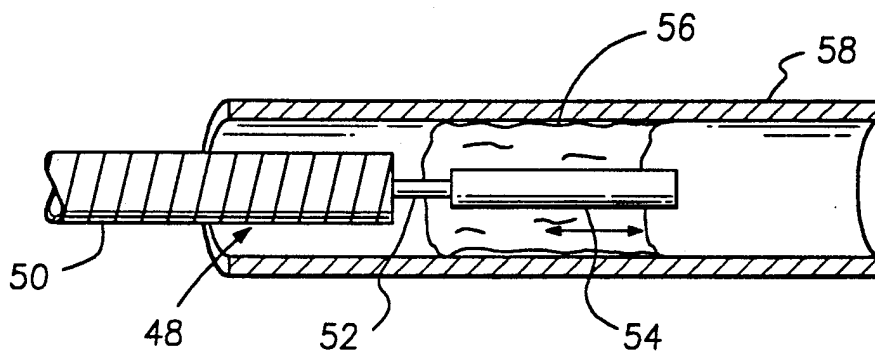

FIG. 5

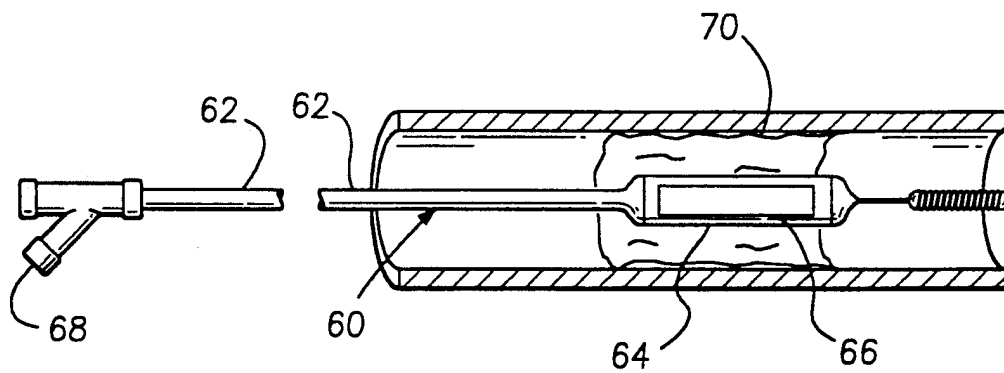

FIG. 6

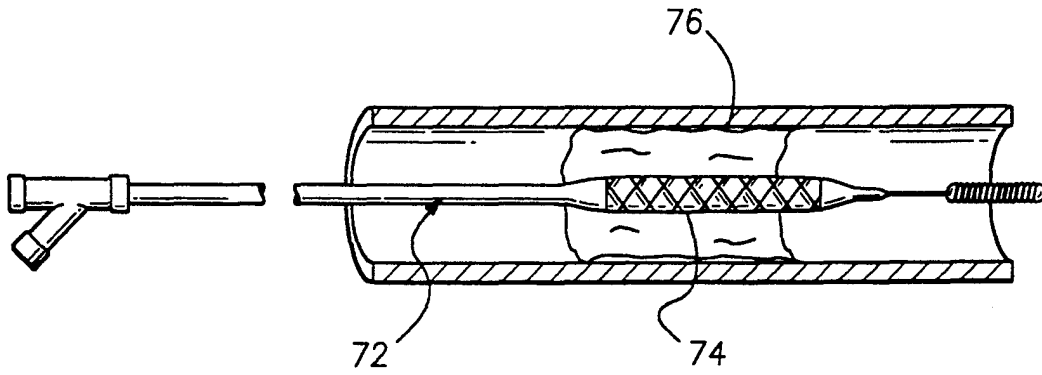

FIG. 7

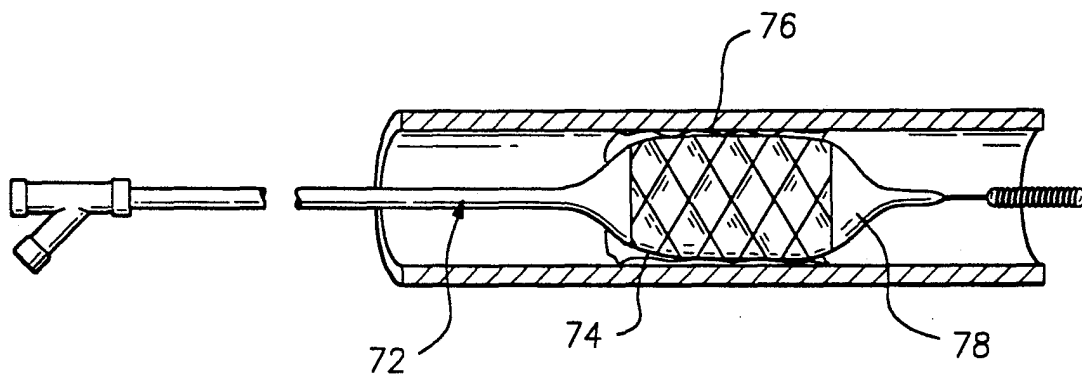

FIG. 8

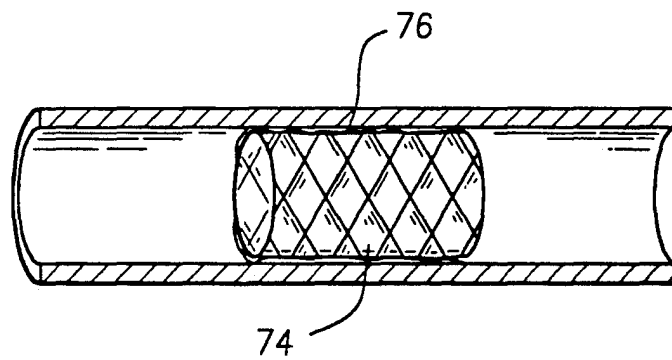

FIG. 9

## METHOD AND APPARATUS FOR RESTENOSIS TREATMENT

### BACKGROUND OF THE INVENTION

This invention relates generally to angioplasty and more particularly to a method and apparatus for preventing restenosis after angioplasty or other stenosis treatment.

### BACKGROUND DESCRIPTION

In the past, catheters have been developed which may be effectively inserted into blood vessels and maneuvered through a vascular tree. A balloon may be used with such catheters to expand in the vessel and open blockages found therein. In a typical percutaneous transluminal coronary angioplasty (PTCA) or percutaneous transluminal angioplasty (PTA) procedure, a guiding catheter is percutaneously introduced into the vascular system of a patient through an artery and advanced therein until the distal tip of the guiding catheter is appropriately positioned. A dilation catheter having a balloon on the distal end thereof and a guide wire are slidably disposed and introduced through the guiding catheter. The guide wire is first advanced through the distal tip of the guiding catheter until the distal end of the guide wire crosses the lesion to be dilated. The dilation catheter is then advanced over the previously introduced guide wire until the dilation balloon on the distal extremity of the dilation catheter is properly positioned inside the lesion. The balloon portion of the dilation catheter is then inflated to a predetermined size to radially compress the atherosclerotic plaque of the lesion against the inside of the artery wall to thereby reduce the annular stenosed area. After a period of time, the balloon is deflated so that blood flow is resumed, allowing the dilation catheter to be removed.

A major problem encountered in a significant number of patients treated by this procedure is the subsequent narrowing of the artery after the expansion treatment. Various methods and apparatus have been developed to address the restenosis problem including multiple inflations of the balloon during the original procedure, atherectomy, hot balloons, and lasers. Even the installation of permanent stents has been thought to potentially have some value in reducing restenosis rates. See, for example, U.S. Pat. No. 5,019,075 to Spears et al. wherein the region surrounding the balloon utilized in the angioplasty procedure is heated by means within the balloon, or within the skin of the balloon, upon inflation of the balloon in order to ideally fuse together fragmented segments of tissue. U.S. Pat. No. 4,733,655 to Palmaz discloses an expansible vascular graft which is expanded within a blood vessel by an angioplasty balloon to dilate and expand the lumen of the blood vessel. The Palmaz method and apparatus leaves the expandable vascular graft in place to ideally prevent recurrence of stenosis in the body passageway.

However, recent data seems to indicate that the prior art methods described above do not significantly reduce restenosis rates of occurrence. In restenosis, a proliferation of cells following angioplasty is believed to cause the lesion to reform. The rate of occurrence of restenosis is generally considered to be about 33 percent. It would therefore be desirable to have a method and apparatus to treat a lesion in order to reduce the restenosis rate of occurrence. The present invention is believed to provide a unique method and apparatus to

reduce the restenosis rate of occurrence following an angioplasty or like-intended procedure.

### SUMMARY OF THE INVENTION

The purpose of the invention is to provide method and apparatus to significantly reduce restenosis rates of occurrence following an angioplasty procedure. To accomplish this purpose, there is provided method and apparatus for exposing the dilated lesion to a radiation dose that will affect smooth muscle cell growth. There is provided a catheter which has at its distal end a radioactive source, the source being maneuverable to the site of a lesion which has been dilated or removed, the apparatus allowing the site to be exposed to the radiation dose that will affect smooth muscle cells such that the rapid growth of such cells can be prevented, thereby controlling restenosis.

In one aspect of the invention there is provided a method for treatment and post-treatment of the stenosed region of an artery comprising the steps of:

- reducing the annular stenosed area within an artery; and
- applying a radioactive dose to the area of reduced stenosis.

In another aspect of the invention there is provided a method for treatment and post-treatment of the stenosed region of an artery after reduction of said region by angioplasty or other means comprising the step of applying a radioactive dose to said reduced region of the artery.

In yet another aspect of the invention there is provided apparatus for post-treatment of a stenosed region of an artery that has been reduced by angioplasty or other means comprising:

- radioactive dose means; and
- positioning means operatively connected to said dose means to position said dose means within the stenosed region of an artery that has been reduced by angioplasty or other means.

### DESCRIPTION OF THE DRAWING

FIG. 1 is a partial cross-sectional view of an embodiment of the invention wherein said dose applying means is a radioactive element contained within a wire wound housing for radioactive containment, the housing having a window cut-out. A larger wire wound sheath covers the window during insertion and removal, the sheath being withdrawn to expose the radioactive element at the lesion site.

FIG. 2 is a partial perspective view of an alternate embodiment having a radioactive dose means positioned upon the balloon of an expandable balloon catheter, said balloon catheter being provided with a means or perfusion to allow blood flow during the time the balloon is inflated.

FIG. 3 is an enlarged partial cross-sectional view of a portion of the apparatus shown in FIG. 2.

FIG. 4 is a partial perspective view of the apparatus shown in FIGS. 2 and 3 upon expansion of the balloon portion of the apparatus.

FIG. 5 is a partial perspective view of another embodiment of the invention wherein the radioactive dose means is an element that may be contained within a complementary containment means provided with a remotely actuated window.

FIG. 6 is a partial perspective cross-sectional view of a catheter tip containing radioactive dose means showing the remotely actuated window.

FIG. 7 is a partial perspective cross-sectional view of an alternate embodiment further including a stent wherein said radioactive dose means is in the form of a coating of radioactive material on the stent.

FIG. 8 is a partial cross-sectional view of the device shown in FIG. 7 after expansion of the stent shown in FIG. 7.

FIG. 9 is a partial perspective view of the stent illustrated in FIGS. 7 and 8 wherein the stent is implanted within the artery.

### DESCRIPTION OF THE PREFERRED EMBODIMENTS

With continued reference to the drawing, FIG. 1 illustrates the apparatus and method for preventing restenosis of an artery that has been enlarged by angioplasty or other procedure. Specifically, apparatus, shown generally at 10, is positioned within artery segment 12 having lesion site 14 which has previously been enlarged by angioplasty or other procedure such that atherosclerotic plaque 16 has been radially compressed by expansion of the balloon portion of an angioplasty device (not shown) or removed by other means. Device 10 having distal end 18 with tip 20 and wire wound housing 22 is positioned such that housing 22 is positioned within the lesion site 14. Housing 22 contains radioactive dose means 30 and is provided with window cut-out 32. Device 10 includes a wire wound retractable sheath 24 and catheter shaft 26 with guide wire and guide wire port 28. A radioactive dose means 30 is moveable by advancing or retracting catheter shaft 26 which may be referred to as a positioning means. Sheath 24 is drawn back when the radioactive dose means is positioned directly proximate the lesion site 14 such that window cut-out 32 is opened to expose the lesion site 14, which has been previously dilated, to a radiation dose that will affect the smooth muscle cells/plaque.

In FIG. 2 there is illustrated a device shown generally at 34 which is an alternate embodiment of the invention further including an angioplasty balloon 36 with dose means in the form of radioactive elements 38 attached thereto. Device 34 includes catheter shaft 40 having perfusion capabilities provided by holes 41 positioned proximally and distally to the balloon portion.

FIG. 3 shows in expanded view details of balloon 36 of FIG. 2 positioned about catheter shaft 40 having two main lumens 42 and 44. Lumen 42 makes provision for guide wire capability and contains perfusion holes. Lumen 44 is the lumen which provides the passage to inflate the balloon from the inflation port 45 shown in FIG. 2 at the proximal end of the device 34. The radioactive elements 38 are not shown in FIG. 3.

FIG. 4 illustrates the device 34 of FIGS. 2 and 3 wherein the balloon 36 is expanded in the vicinity of the lesion site 46, and the radioactive elements 38 are forced into contact with the lesion.

It is understood that the various embodiments of the subject invention are useful in the treatment of a lesion site within an artery. "Lesion site" includes those lesions which have been treated with balloon angioplasty, those lesions that have been treated by an atherectomy or laser angioplasty, those lesions that have been treated by rotational atherectomy or any other means of compressing or removing the material of the lesion which may cause trauma to the artery. It is this trauma which

causes the proliferation of smooth muscle cells which method and apparatus of the subject invention is intended to inhibit.

With regard to all embodiments of the subject invention, "radioactive dose" means bombardment by particles emitted from radioactive materials including, but not limited to, materials such as Radon 222, Gold 198, Strontium 90, Radium 192, and Iodine 125. These materials may be incorporated into or delivered in a solid, liquid, or gaseous form, and the delivery of such forms is considered to be within the scope of the subject invention.

FIG. 5 illustrates an alternate embodiment of the subject invention in the form of apparatus shown generally at 48. Sheath 50 of said device is preferably made from a helically wire wound member to provide a measure of shielding for the radioactive dose means. Device 48 includes positioning means 52 which is a motion wire providing slidable motion of the radioactive dose means 54 within the sheath. Radioactive dose means 54 is thus positionable proximate to the lesion site 56 of artery segment 58 and retractable within sheath 50 for insertion and removal within the artery segment 58.

FIG. 6 illustrates yet another embodiment of the subject invention in the form of the device shown generally at 60, similar to the device 10 shown in FIG. 1. In FIG. 6, device 60 is comprised of the shaft portion 62 and contains at its distal end a canister 64 containing the radioactive dose means. This canister 64 has a remotely actuated window 66 which can be actuated through port 68 to expose the radioactive dose means to the lesion 70.

FIGS. 7, 8, and 9 illustrate yet another embodiment of the subject invention wherein a device shown generally at 72 is an inflatable stent delivery balloon system for delivery and expansion of stent 74. Stent 74 may be removable or may be a permanent implant. In the case of a permanently implanted stent, the radioactive dose means has to be carefully chosen in terms of dose level and half-life in order to limit the total radiation dose. In this embodiment, the radioactive dose means is associated with stent 74 and may be included as a cladding, a coating, an additive within the basic stent material itself, or an attachment by other means to the stent. In FIG. 7 the device 72 includes an inflatable balloon dilation catheter to position stent 74 within lesion 76.

FIG. 8 shows the expanded balloon of the stent delivery system 78 having dilated stent 74 in close proximal contact with lesion 76.

FIG. 9 shows the stent 74 in place within lesion 76 with the stent delivery system having been removed from the artery.

The foregoing description of the drawing illustrates various methods of the invention. It should be understood that the methods of the invention include the treatment and post-treatment of an annularly stenosed region of an artery. Most methods of treatment currently available cause some trauma to the artery. The artery in response to this trauma proliferates the growth of smooth muscle cells in many cases, and this results in restenosis at the site of the original stenosis—usually within a six-month period. The post-treatment consists of exposing the treated region of the stenosis to a radiation dose which is sufficient to retard or halt the proliferation of smooth muscle cells. It should also be pointed out that both the treatment and post-treatment could occur simultaneously if the device which removes or

5

compresses the stenosis material also contains the radioactive dose means.

Having indicated above preferred embodiments of the present invention, it will occur to those skilled in the art that modification and alternatives can be practiced within the spirit of the invention. It is accordingly intended to define the scope of the invention only as indicated in the following claims.

What is claimed is:

- 1. A method for treatment and post-treatment of a stenosed area of an artery comprising the steps of:
  - reducing the annular stenosed area within an artery;
  - advancing a radioactive dose means within the artery to the area of reduced stenosis, the radioactive dose means being operatively connected to positioning means and the advancing step being performed by moving the positioning means;
  - applying a radioactive dose to the area of reduced stenosis by exposing the area of reduced stenosis to the radioactive dose means; and

6

removing the dose means from the artery by moving the positioning means.

- 2. A method as defined in claim 1 wherein the step of applying the radioactive dose is sufficient to affect smooth muscle cells within the area of reduced stenosis to inhibit rapid growth of such cells, thereby preventing restenosis of the artery.

- 3. A method as defined in claim 1 further including a step of continuing to reduce the annular stenosed area while applying a radioactive dose to said area.

- 4. A method as defined in claim 1 including a step of allowing blood flow through the area of reduced stenosis while applying the radioactive dose.

- 5. A method as defined in claim 1 including the contacting of the tissue of the area of reduced stenosis with the radioactive dose.

- 6. A method as defined in claim 1 further including a step of containing a source of radioactive dose before and after exposure to said area of reduced stenosis.

\* \* \* \* \*

20

25

30

35

40

45

50

55

60

65